



通用汽油机零部件图册

PARTS CATALOGUE FOR LIFAN GENERAL GASOLINE ENGINE



190FD

重庆力帆内燃机有限公司

Chongqing Lifan Power Co.,Ltd.

说 明 PREFACE

LF190D 通用汽油机是重庆力帆内燃机有限公司采用国内外先进技术自行研制开发的单缸、倾斜式、四冲程、强制风冷汽油机。该机具有设计先进、结构紧凑、性能可靠、维修方便、使用经济、调速方便等特点，其配套用途广泛，是发电、旅游、野外作业、娱乐场所、建筑机械、农业机械、林业机械等领域的理想配套动力。

《LF190FD 通用汽油机零部件图册》是我公司为了方便用户精心编制而成，该图册涵盖了零部件的基本情况，如：简图、名称、数量等，用户订购零件时请参考本册，若与实机不同之处，以实机为准。

《LF190FD 通用汽油机零部件图册》的所有版权属于重庆力帆内燃机有限公司，任何团体和个人不得非法翻印或复制。如有更改，恕不另行通知。

Combine with all the specialty and advantages of the same models at home and abroad, LF190FD, being of 4-stroke, single cylinder with force air-cooled type, is one of the newly gasoline engines developed by our Co. It is characterized by advanced design, compact struction, reliable performance, convenient service, low fuel consumption and easy regulation. The engine is widely used as ideal power in many fields such as generating set, tour, open working, public place of entertainment, construction machine, agricultural machinery, etc.

For the sake of customer's convenience, we carefully compile the **PART CATALOGUE FOR LF 190FD ENGINE**, which covers the main informations of parts, such as illustrations, names, quantities, etc. Please refer to this book when you order the parts. If any difference in the book from the actual engine status, please do as per the real.

The copyright of this catalogue belongs to Chongqing Lifan Power Co., Ltd. Any group or individual is forbidden to reprint or copy any item from it. The cotalogue is subject to change without notice.

重庆力帆内燃机有限公司

Chongqing Lifan Power Co., Ltd.

二〇〇六年七月第一版(Feb, 2006 Second Edition)

目 录

CONTENTS

E-1	曲轴箱总成.....	1
	CRANKCASE ASSY	
E-2	曲轴箱盖组件.....	2
	CRANKCASE COVER ASSY	
E-3	气缸头 气缸头盖总成.....	4
	CYLINDER HEAD & CYLINDER HEAD COVER ASSY	
E-4	曲轴 活塞连杆 平衡轴总成.....	6
	CRANKSHAFT, PISTON, CONNECTING & BALANCING SHAFT	
E-5	凸轮轴装配组合 气门摇臂组合.....	8
	COMBINATION OF CAM SHAFT & VALVE ROCKER	
E-6	化油器总成	10
	CARBURETOR ASSY	
E-7	燃油箱组成.....	12
	FUEL TANK ASSY	
E-8	空气滤清器总成.....	13
	AIR CLEANER ASSY	
E-9	消声器组件.....	14
	MUFFLER	

E-10	反冲起动机部件.....	15
	RECOIL STARTER	
E-11	调速控制系统.....	17
	REGULATING CONTROL SYSTEM)	
E-12	飞轮部件.....	19
	FLYWHEEL	
E-13	点火线圈组件.....	20
	IGNITION COIL	
E-14	起动机部件.....	21
	STARTING MOTOR ASSY	
E-15	起动机控制盒总成.....	23
	STARTING MOTOR CONTROL BOX ASSY	
E-16	贴花.....	25
	EMBLEM	

E-1 曲轴箱总成 CRANKCASE ASSY

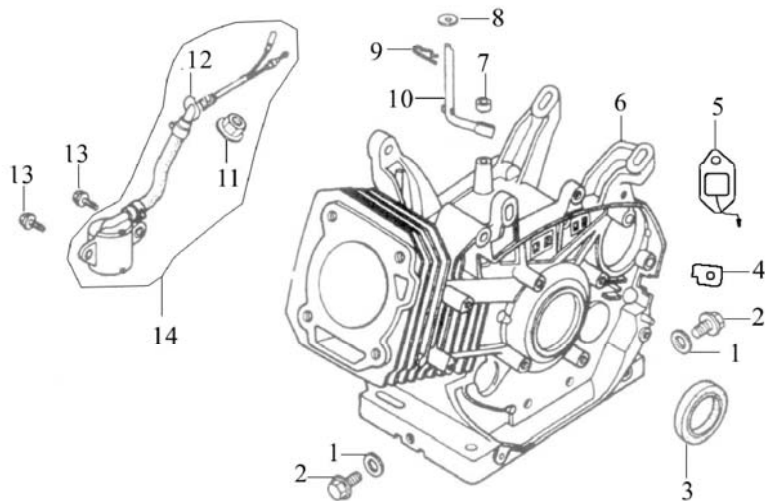

序号 S/N	零 部 件 代 号 Part No.	零 部 件 名 称	Description	数 量 Quantity	备 注 Remark
1	11213/173F	放油螺塞垫圈	Washer	2	
2	11212/173F	放油螺塞	Drain plug	2	
3	13180/182F	曲轴油封	Oil seal, crankshaft	1	
4	11124/173F	曲轴箱橡胶圈	Seal	1	
5	37850/168F	单向导通器	Diode	1	
6	11100	曲轴箱组合	Crankcase	1	
7	26390/173F	调速摆杆油封	Oil seal, regulating sway bar	1	
8	26329/173F	调速摆杆垫片	Washer	2	
9	26321/173F	调速摆杆锁夹	Split pin	1	
10	26311/182F	调速摆杆	Regulating sway bar	1	
11	GB6177-86	螺母 M10	Nut M10	1	
12	GB3452.1-92	O 型密封圈 13×1.4	O-ring	1	
13	GB5787-86	螺栓 M6×14	Bolt M6×14	1	
14	37810/173F	机油传感器	Oil sensor	2	
				1	

E-2 曲轴箱盖组件 CRANKCASE COVER ASSY

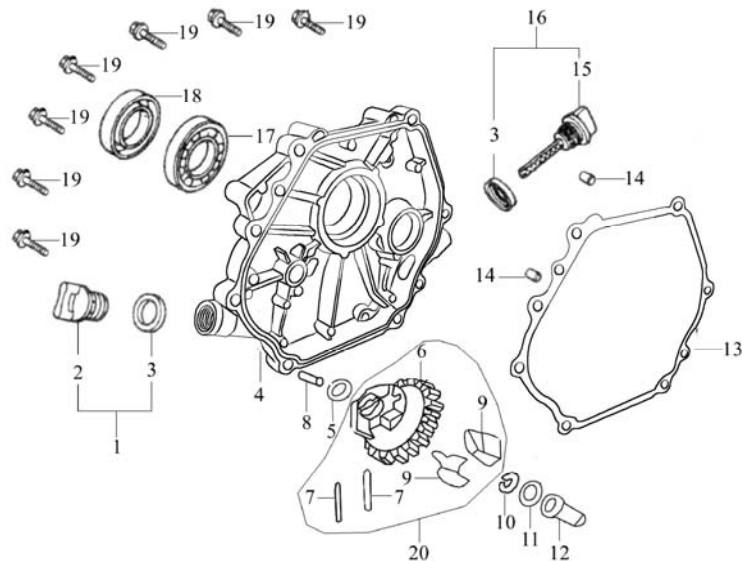

序号 S/N	零 部 件 代 号 Part No.	零 部 件 名 称	Description	数 量 Quantity	备 注 Remark
1	15650/173F	机油塞组件	Oil plug with Seal	1	
2	15651/173F	机油塞	Oil plug	1	
3	15612/173F	机油尺密封圈	Seal	1	
4	11311/182F	曲轴箱盖	Crankcase cover	1	
5	25165/173F	调速从动齿轮垫片	Washer, driven gear	1	
6	25121/182F	调速从动齿轮	Driven gear, regulator	1	
7	25163/173F	飞块销	Pin	2	
8	25151/173F	调速轴	Regulating shaft	1	
9	25141/182F	调速飞块	Flying block	2	
10	25164/173F	调速轴卡圈	Snap ring	1	
11	25132/168F	调速滑套垫片	Washer	2	
12	25131/173F	调速滑套	Sliding sleeve	1	

E-2 曲轴箱盖组件 CRANKCASE COVER ASSY

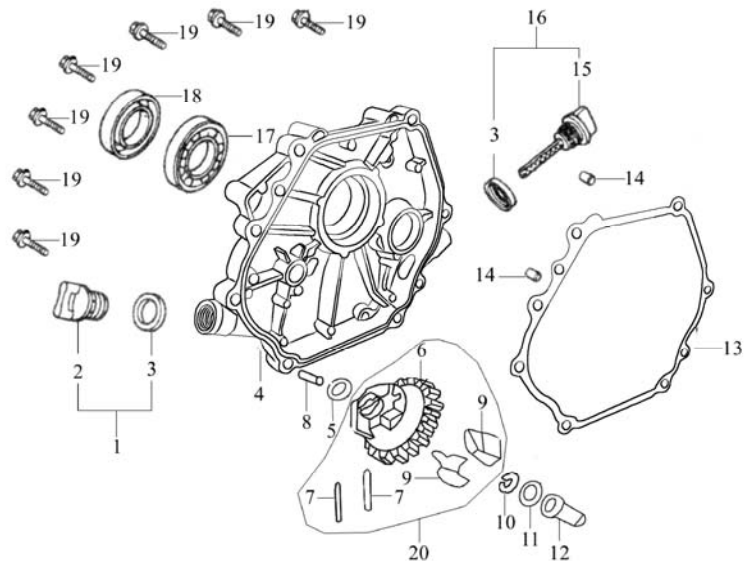

序号 S/N	零 部 件 代 号 Part No.	零 部 件 名 称	Description	数 量 Quantity	备 注 Remark
13	11119/182F	曲轴箱垫片	Gasket, crankcase	1	
14	11118/173F	定位销Φ8×12	Set pin Φ8×12	2	
15	15611/173F	机油尺	Dipstick	1	
16	15610/173F	机油尺组件	Dipstick with seal	1	
17	GB276-89	轴承 6207	Bearing 6206	1	
18	13180/182F	曲轴油封	Oil seal, crankshaft	1	
19	GB5787-86	螺栓 M8×40	Bolt M8×40	7	
20	25120/182F	调速从动齿轮组件	Driven gear, regulator assy	1	

E-3 气缸头 气缸头盖总成 CYLINDER HEAD & CYLINDER HEAD COVER ASSY

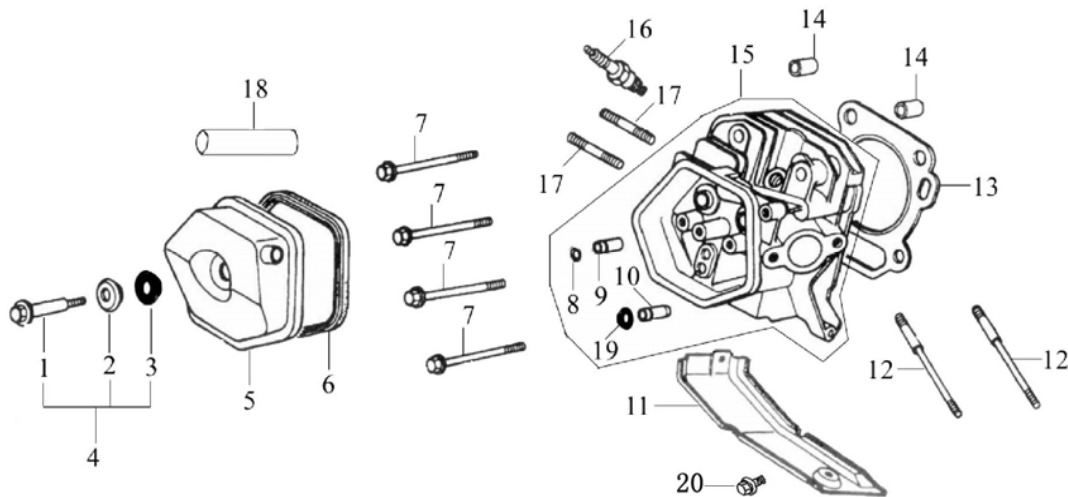

序号 S/N	零 部 件 代 号 Part No.	零 部 件 名 称	Description	数 量 Quantity	备 注 Remark
1	12411/173F	气缸头盖螺栓	Bolt	1	
2	12412/173F	气缸头盖螺栓垫圈	Washer	1	
3	12421/173F	橡胶圈	Rubber seal	1	
4	12410/173F	气缸头盖螺栓组件	Bolt	1	
5	12310/173F	气缸头盖组合	Cylinder head cover Assy	1	
6	12312/173F	气缸头盖密封圈	Gasket, cylinder head cover	1	
7	12256/173F	气缸头螺栓	Bolt	4	
8	12219/173F	排气门导管卡圈	Circlip	1	
9	12215/173F	排气门导管	Exhaust valve guide	1	
10	12214/173F	进气门导管	Intake valve guide	1	
11	19721/182F	下导风罩	Lead wind cover	1	
12	12252/182F	进气口双头螺栓 M6×M8×134.5	Stud M6×M8×134.5	2	
13	12220	气缸头密封垫	Gasket, cylinder head	1	
14	12218/173F	气缸头定位销	Set pin	2	
15	12210	气缸头组合	Cylinder head Assy	1	

E-3 气缸头 气缸头盖总成 CYLINDER HEAD & CYLINDER HEAD COVER ASSY

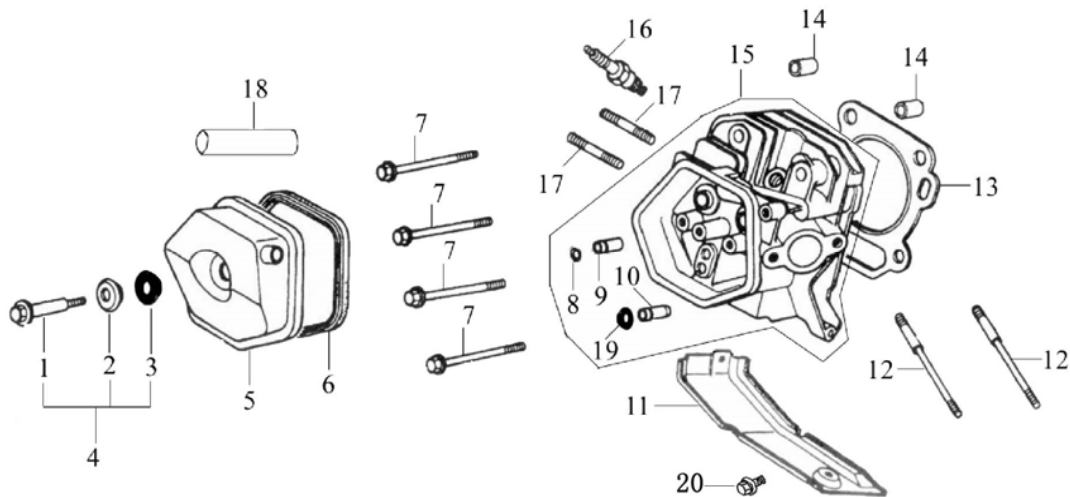

序号 S/N	零 部 件 代 号 Part No.	零 部 件 名 称	Description	数 量 Quantity	备 注 Remark
16	34200/173F	火花塞 F7RTC	Spark plug F7RTC	1	
17	12253/173F	排气口双头螺栓 M8×48.5	Stud M8×48.5	2	
18	20651/173F	通气管	Air duck	1	
19	14730/173F	挡油罩	Seal	1	
20	GB5787-86	螺栓 M6×12	Bolt:M6×12	2	

E-4 曲轴 活塞连杆 平衡轴总成 CRANKSHAFT, PISTON, CONNECTING & BALANCING SHAFT

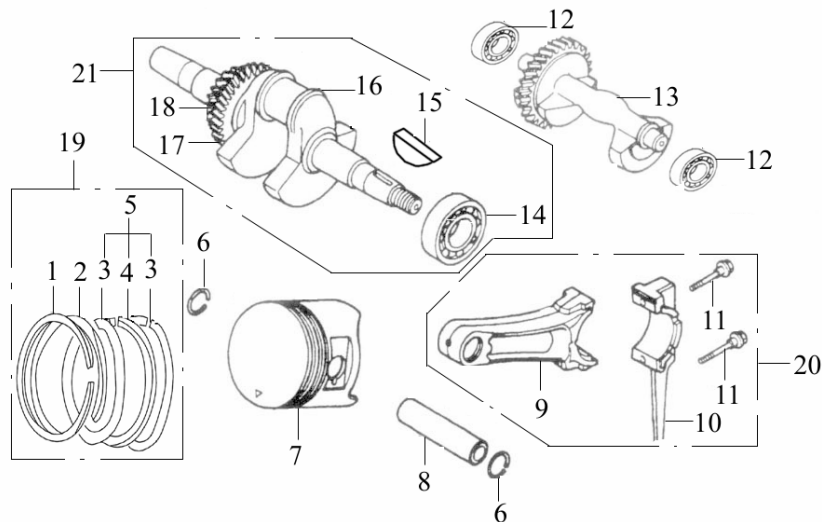

序号 S/N	零部件代号 Part No.	零部件名称	Description	数量 Quantity	备注 Remark
1	13311	活塞环 (一)	Piston ring (I)	1	
2	13312	活塞环 (二)	Piston ring (II)	1	
3	13322	侧环	Side rail	2	
4	13321	衬簧	Expander	1	
5	13320	油环组合	Scraper ring set	1	
6	13222/182F	活塞销挡圈	Piston pin circlip	2	
7	13211	活塞	Piston	1	
8	13221/188F	活塞销	Piston pin	1	
9	13131	连杆	Shank	1	
10	13132/182F	连杆盖	Connecting rod cover	1	
11	13133/173F	连杆螺栓	Bolt	2	
12	GB276-89	轴承 6202	Bearing 6202	2	
13	13611	平衡轴	Balancing shaft	1	
14	GB276-89	轴承 6207	Bearing 6207	1	

E-4 曲轴 活塞连杆 平衡轴总成 CRANKSHAFT, PISTON, CONNECTING & BALANCING SHAFT

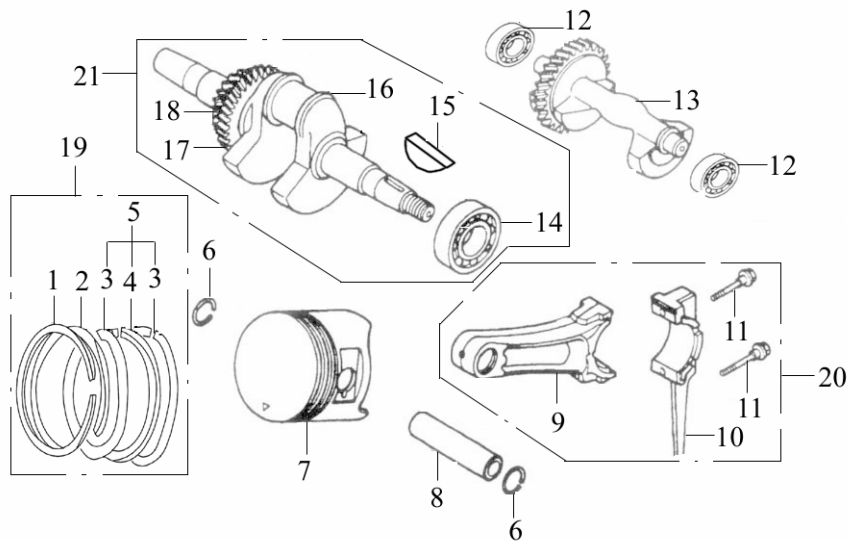

序号 S/N	零部件代号 Part No.	零部件名称	Description	数量 Quantity	备注 Remark
15	13118/173F	半圆键	Wood ruff key	1	
16	13111	曲轴	Crankshaft	1	
17	25111/182F	调速主动齿轮	Drive gear	1	
18	14211/182F	正时主动齿轮	Timing driving gear	1	
19	13300	活塞环组	Piston ring set	1	
20	13130	连杆组合	Connecting rod assy	1	
21	13110	曲轴组合	Crankshaft assy	1	

E-5 凸轮轴装配组合 气门摇臂组合 COMBINATION OF CAM SHAFT & VALVE ROCKER

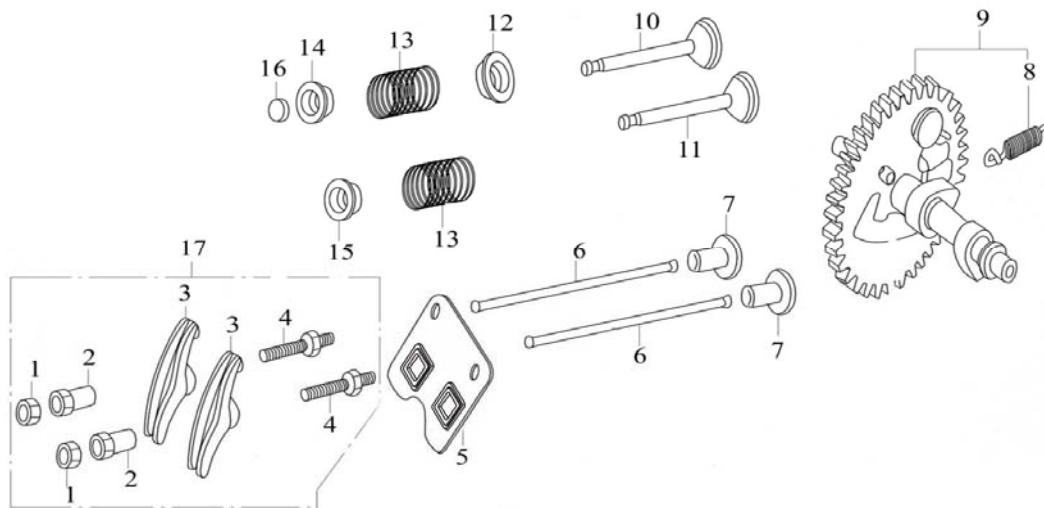

序号 S/N	零部件代号 Part No.	零部件名称	Description	数量 Quantity	备注 Remark
1	14416/173F	气门间隙调节螺母	Lock nut	2	
2	14413/173F	摇臂轴座销	Sleeve	2	
3	14411/173F	气门摇臂	Valve rocker	2	
4	14415/173F	气门间隙调节螺栓	Adjusting bolt for valve gap	2	
5	14261/173F	推杆导架	Pusher guide	1	
6	14250/182F	推杆组合	Pusher	2	
7	14455/173F	挺柱	Tappet	2	
8	14146/173F	飞块弹簧	Extension spring	1	
9	14100	凸轮轴装配组合	Camshaft assy	1	
10	14721/182F	排气门	Exhaust valve	1	
11	14711/182F	进气门	Intake valve	1	
12	14753/173F	排气门弹簧下座	Spring retainer, exhaust valve	1	
13	14755/173F	气门弹簧	Valve spring	2	
14	14757/173F	排气门弹簧座	Spring seat, exhaust valve	1	

E-5 凸轮轴装配组合 气门摇臂组合 COMBINATION OF CAM SHAFT & VALVE ROCKER

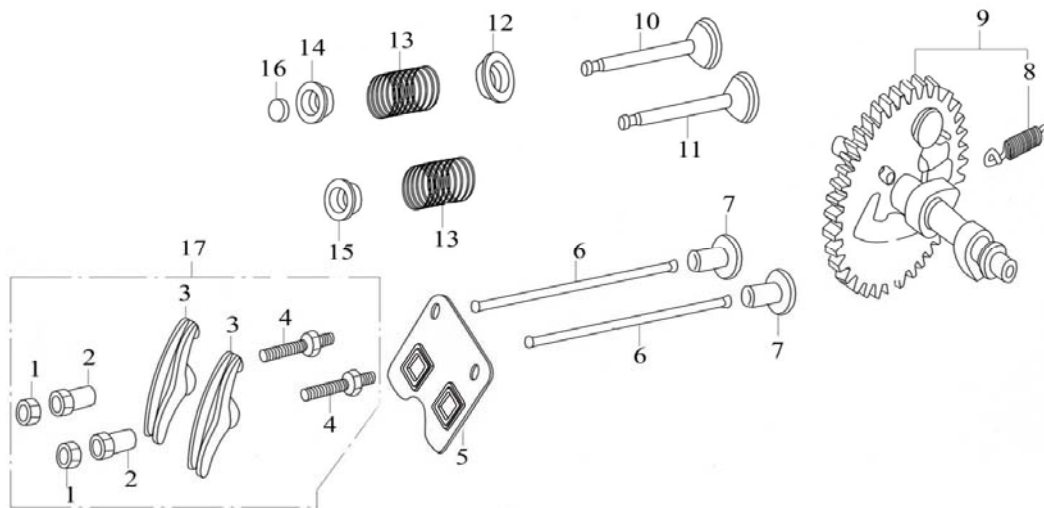

序号 S/N	零部件代号 Part No.	零部件名称	Description	数量 Quantity	备注 Remark
15	14751 /173F	进气门弹簧座	Spring seat, intake valve	1	
16	14758 /173F	排气门顶帽	Cap	1	
17	14410 /173F	气门摇臂装配组合	Valve rocker assy	1	
				2	

E-6 化油器总成 CARBURETOR ASSY

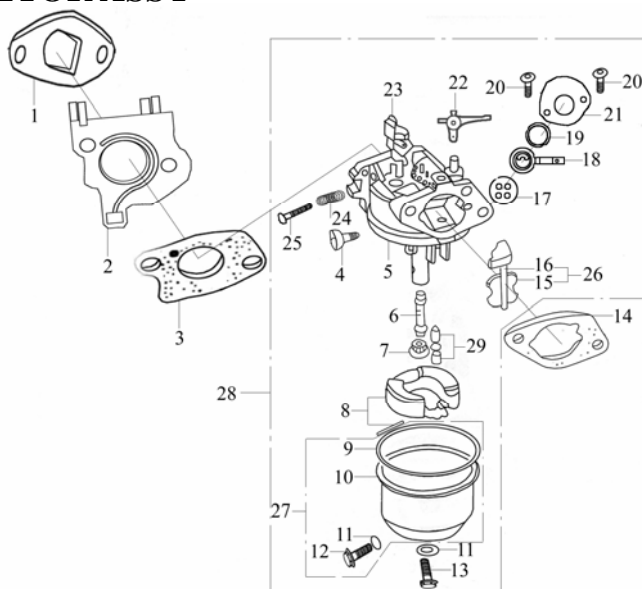

序号 S/N	零部件代号 Part No.	零部件名称	Description	数量 Quantity	备注 Remark
1	12254/182F	进气口垫片	Inlet gasket	1	
2	16141/188F	化油器接块	Connecting block	1	
3	16142	化油器垫片	Carburetor gasket	1	
4	16421/168F	怠速调整螺钉	Idle adjustment screw	1	
5	16250	化油器混合室体	Mixture chamber body	1	
6	16251	主喷油管	Main nozzle	1	
7	16254	主喷油嘴	Main jet	1	
8	16230/182F	浮子组合	Float	1	
9	16219/173F	浮子室密封垫	Float chamber gasket	1	
10	16211/173F	浮子室	Float chamber	1	
11	16216/168F	浮子室放油螺钉垫圈	Washer	2	
12	16215/168F	浮子室放油螺钉	Float chamber drain Screw	1	
13	16213/168F	底部螺钉	Screw	1	
14	17330/173F	空滤器垫片	Air cleaner gasket	1	

E-6 化油器总成 CARBURETOR ASSY

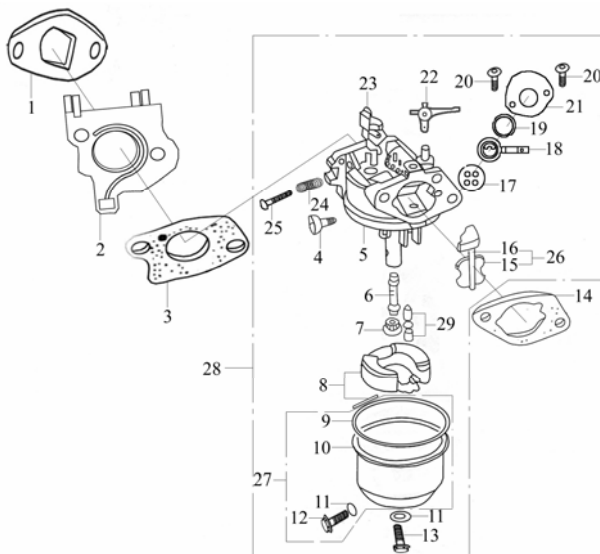

序号 S/N	零部件代号 Part No.	零部件名称	Description	数量 Quantity	备注 Remark
15	16331/173F	阻风门	Choke	1	
16	16332/173F	阻风门轴	Choke stem	1	
17	16312/168F	油门控制臂密封圈	Airproof washer	1	
18	16311/168F	油门控制臂	Throttle lever	1	
19	16313/168F	油门控制臂钢垫片	Washer	1	
20	GB5787-86	螺钉 M4	Screw M4	2	
21	16314/168F	油门控制臂固定盖	Cover	1	
22	16148/173F	阻风门开关	Choke switch	1	
23	16280	节气门组合	Throttle unit	1	
24	16422/168F	混合比调整螺钉弹簧	Spring, mixture adjustment screw	1	
25	16425/168F	混合比调整螺钉	Mixture adjustment screw	1	
26	16330/173F	阻风门组合	Choke unit	1	
27	16210/173F	浮子室组合	Float chamber	1	
28	16100	化油器总成	Carburetor Assy	1	
29	16240/182F	浮子油针组合	Float needle	1	

E-7 燃油箱组成 FUEL TANK ASSY

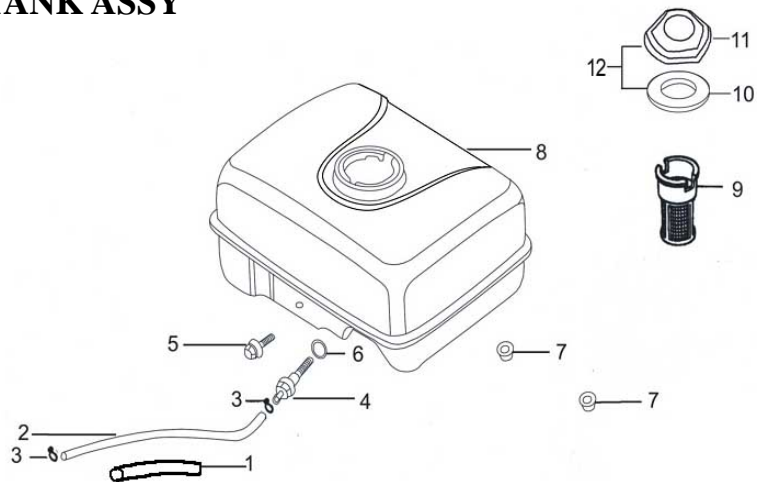

序号 S/N	零部件代号 Part No.	零部件名称	Description	数量 Quantity	备注 Remark
1	16932/173F	隔热管	Pipe	1	
2	16931/173F	出油管 (一)	Outlet pipe	1	
3	16937/168F	油管夹 (二)	Pipe clamp	2	
4	16950/168F	出油接头	Connector	1	
5	GB5787-86	螺栓 M8×25	Bolt M8 × 25	1	
6	16961/168F	出油接头密封圈	Packing ring	1	
7	GB6177-86	螺母 M8	Nut M8	2	
8	16610/182F	燃油箱	Fuel tank	1	
9	16916/168F	过滤杯	Filter cup	1	
10	16521/168F	燃油箱盖密封圈	Packing ring	1	
11	16510/168F	燃油箱盖	Fuel filler cap	1	
12	16500/168F	燃油箱盖组合	Fuel filler cap with packing ring	1	

E-8 空气滤清器总成 AIR CLEANER ASSY

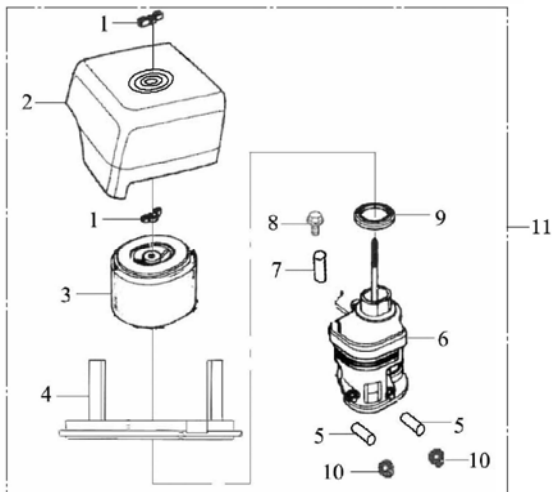

序号 S/N	零 部 件 代 号 Part No	零 部 件 名 称	Description	数 量 Quantity	备 注 Remark
1	GB62-88	蝶形螺母	Wing nut	2	
2	17111/182F	空滤器盖	Air cleaner cover	1	
3	17130/182F	滤芯组件	Filter element	1	
4	17141/182F	空滤器底盖	Air cleaner base	1	
5	17126/173F	轴环 A	Sleeve A	1	
6	17131/173F	空滤器座	Air cleaner housing	1	
7	17146/173F	轴环 B	Sleeve B	1	
8	GB5787-86	空滤器座紧固螺栓 M6×22	Bolt M6×22	1	
9	17125/173F	垫圈	Washer	1	
10	GB6170-86	螺母 M6	Nut M6	2	
11	17100/182F	空滤器总成	Air cleaner assy	1	

E-10 反冲起动器部件 RECOIL STARTER

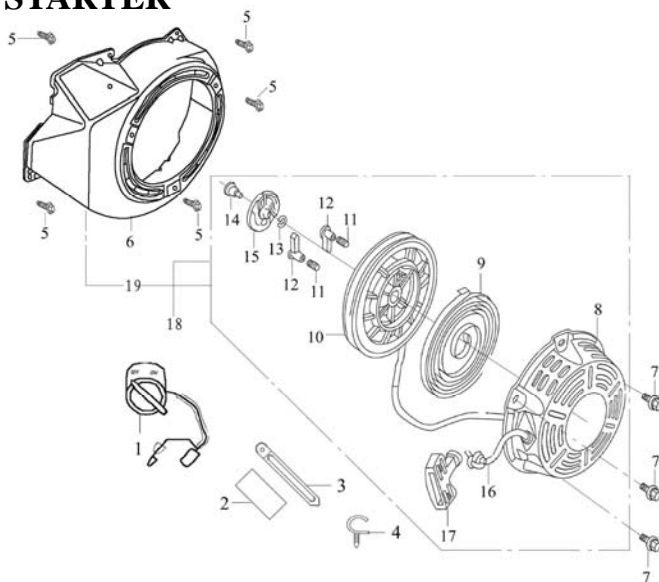

序号 S/N	零部件代号 Part No	零部件名称	Description	数量 Quantity	备注 Remark
1	35410/168F	点火开关	Engine switch	1	
2	32412/173F	护线套	Wire grommet	1	
3	32413/173F	线卡	Clip	1	
4	16146/173F	塑料管架	Plastic clip	1	
5	GB5787-86	螺栓 M6×12	Bolt M6×12	5	
6	19710/182F	风扇罩组件	Fan hood assy	1	
7	GB5787-86	螺栓 M6×8	Bolt M6×8	3	
8	27380/182F	外壳组件	Casing	1	
9	27319/182F	盘簧	Spiral spring	1	
10	27351/182F	起动器卷轴	Starter rolls	1	
11	27312/173F	棘爪弹簧	Ratchet spring	2	
12	27331/173F	棘爪	Ratchet	2	
13	27311/173F	摩擦弹簧	Friction spring	1	
14	27315/173F	轴位螺钉	Set screw	1	

E-10 反冲起动器部件 RECOIL STARTER

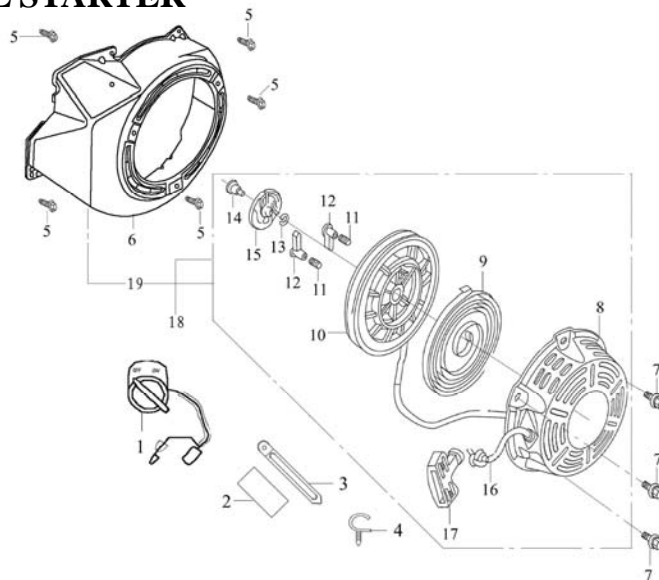

序号 S/N	零部件代号 Part No	零部件名称	Description	数量 Quantity	备注 Remark
15	27341/173F	弹簧盖	Spring lid	1	
16	27313/168F	拉绳	Rope	1	
17	27361/168F	拉手	Pulling handle	1	
18	27300/182F	反冲起动器	Recoil starter	1	
19	27100/182F	反冲起动器总成	Recoil starter assy	1	

E-11 调速控制系统 REGULATING CONTROL SYSTEM

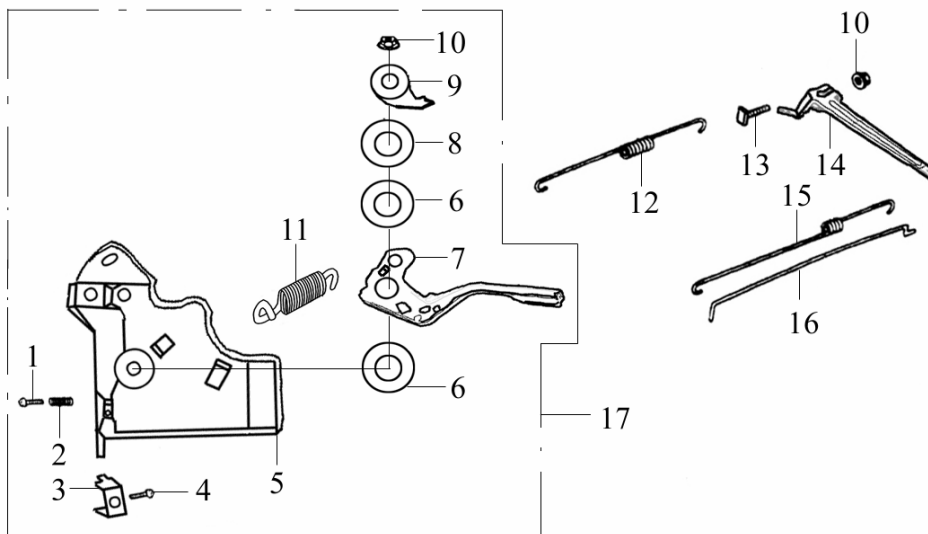

序号 S/N	零部件代号 Part No	零部件名称	Description	数量 Quantity	备注 Remark
1	GB818-85-H	螺栓 M5×35	Bolt M5×35	1	
2	26415/173F	调速弹簧	Regulating spring	1	
3	26422/173F	执行器压板	Clamp	1	
4	GB5787-86	螺栓 M6×12	Bolt M6×12	1	
5	26421/182F	调速支撑板	Support panel	1	
6	26419/173F	垫圈	Washer	2	
7	26412/182F	手柄	Handgrip	1	
8	26418/173F	弹簧片	Spring patch	1	
9	26414/173F	定位板	Setting panel	1	
10	GB6177-86	螺母 M6	Nut M6	2	
11	26416/173F	拉簧	Spring	1	
12	26363	复位弹簧	Back spring	1	
13	26362/168F	调速臂紧固螺栓	Lock bolt	1	
14	26331/182F	调速臂	Regulating arm	1	

E-11 调速控制系统 REGULATING CONTROL SYSTEM

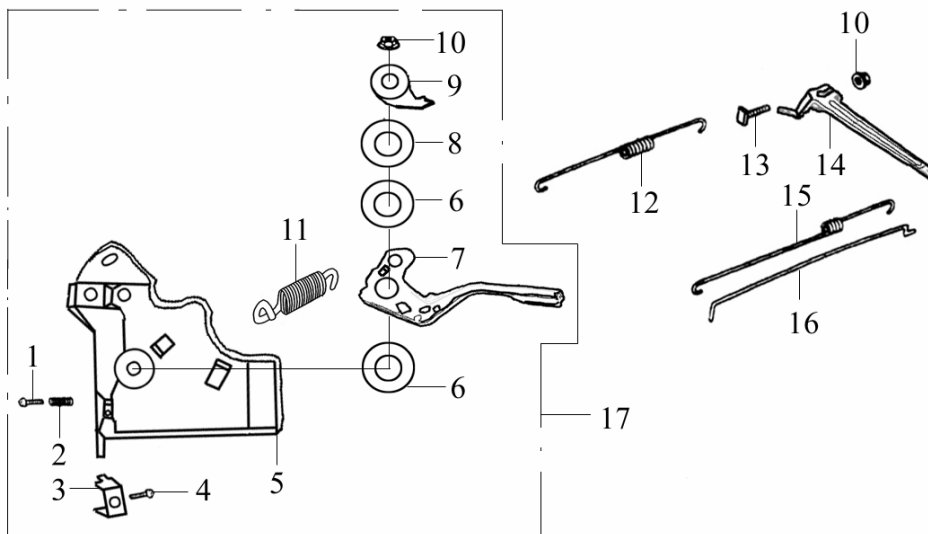

序号 S/N	零部件代号 Part No	零部件名称	Description	数量 Quantity	备注 Remark
15	26364/182F	微调速弹簧	Fine regutaling spring	1	
16	26341/182F	调速拉杆	Pulling rod	1	
17	26410/182F	调速架部件	Regulating frame assy	1	

E-12 飞轮部件 FLYWHEEL

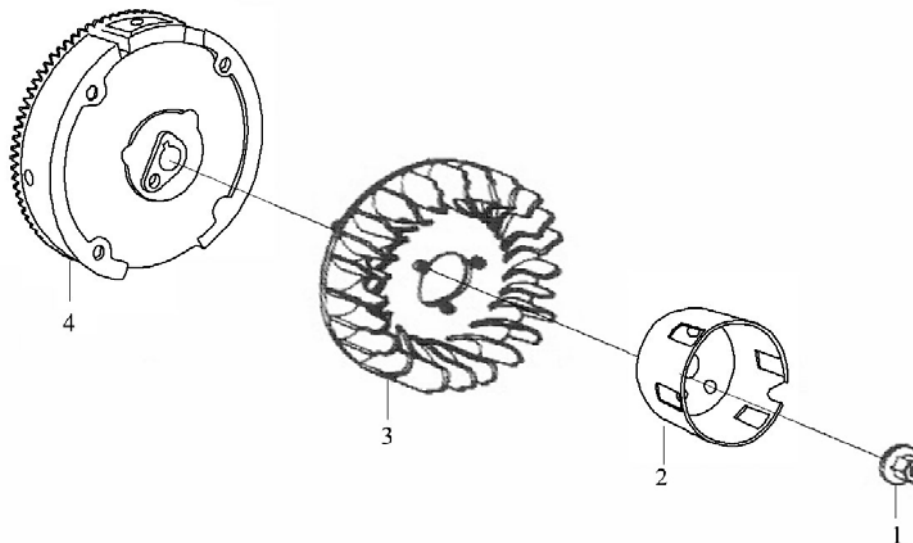

序号 S/N	零部件代号 Part No	零部件名称	Description	数量 Quantity	备注 Remark
1	27515/173F	飞轮螺母 M16×1.25	Nut M16×1.25	1	
2	27370/182F	起动套	Starting flange	1	
3	19722/182F	飞轮风扇	Flywheel fan	1	
4	27500/182F	飞轮组件	Flywheel	1	

E-13 点火线圈组件 IGNITION COIL

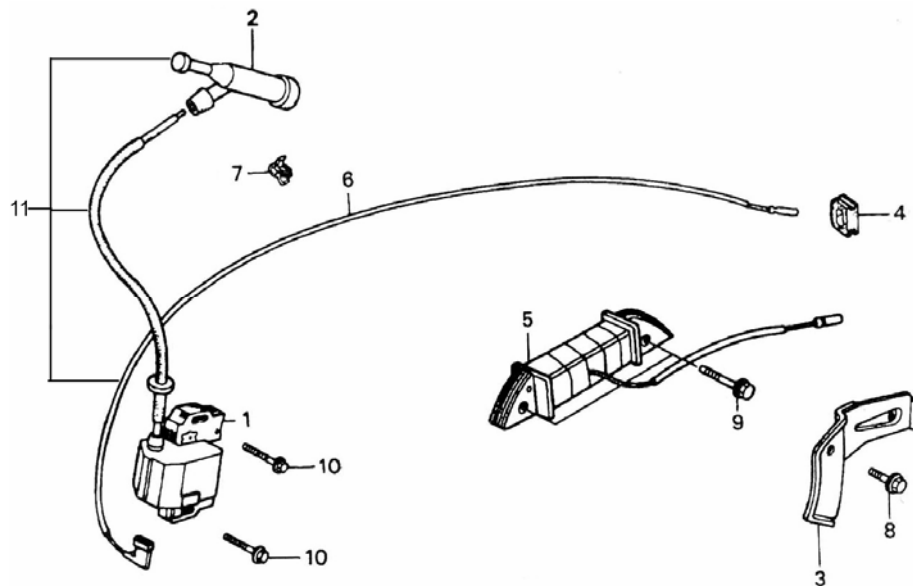

序号 S/N	零部件代号 Part No	零部件名称	Description	数量 Quantity	备注 Remark
1	34510/182F	点火线圈	Ignition coil	1	
2	34310/173F	火花塞帽	Cap, spark plug	1	
3	32213/182F-AS	压线板	Clamper, cord	1	
4	11124/173F	曲轴箱橡胶圈	Rubber ring, crankcase	1	
5	31250/182F-AS	充电定子组件	Charge coil	1	
6	34410/182F	熄火线	Extinguishing cable	1	
7	32212/173F	线夹	Cable tie	1	
8	GB5787-86	螺栓 M6×12	Bolt, M6×12	1	
9	GB5787-86	螺栓 M6×35	Bolt, M6×35	2	
10	GB5787-86	螺栓 M6×30	Bolt, M6×30	2	
11	34500/182F	点火线圈组件	Ignition coil unit	1	

E-14 起动电机部件 STARTING MOTOR ASSY

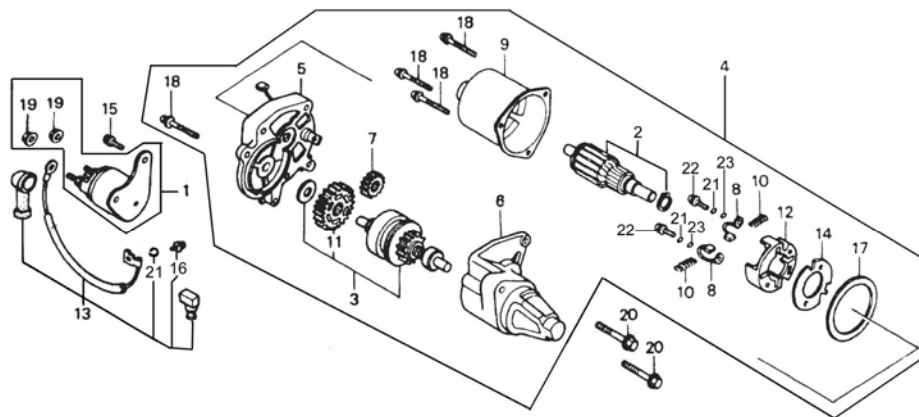

序号 S/N	零部件代号 Part No.	零部件名称	Description	数量 Quantity	备注 Remark
1	38200/182FD	起动继电器	Relay, start-up	1	
2	28610/182D	转子组件	Rotor comp.	1	
3	28100/182FD	起动离合器	Starting clutch	1	
4	28000/182FD	电起动总成	Starting motor Assy	1	
5	28650/182FD	起动电机座	Base, starting	1	
6	28110/182FD	起动离合器壳	Housing, starting clutch	1	
7	28311/182FD	主动齿轮	Driven gear	1	
8	28630/182FD	电刷组件	Brush comp.	4	
9	28620/182FD	定子组件	Stator comp.	1	
10	28631/182FD	电刷弹簧	Spring, brush	4	
11	28321/182FD	减速齿轮	Reducing gear	1	
12	28641/182FD	电刷支架	Stay, brush	1	
13	32160/182FD	起动电机线	Cable, starting motor	1	
14	28632/182FD	绝缘块	Insulator	1	
15	31996/2GF-3	螺栓 M5×14	Bolt, M5×14	2	
16	GB818-85	螺钉 M4×6	Screw, M4×6	1	

E-14 起动电机部件 STARTING MOTOR ASSY

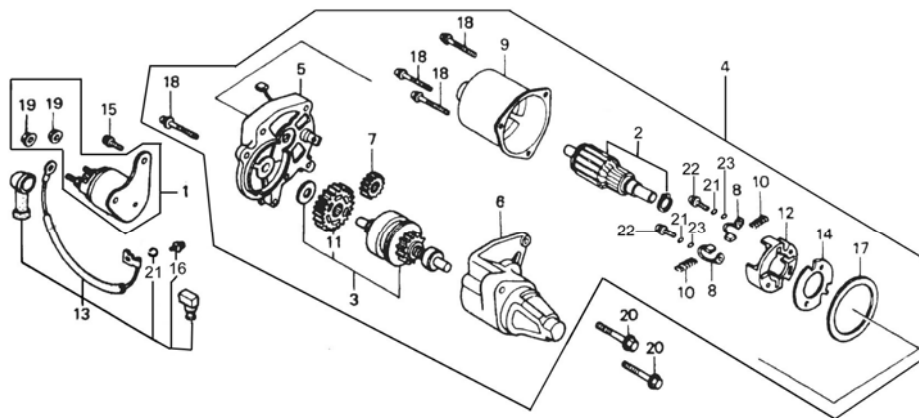

序号 S/N	零部件代号 Part No.	零部件名称	Description	数量 Quantity	备注 Remark
17	28651/182F-AS	密封胶圈	Packing ring	1	
18	GB818-85	螺钉 M5×32	Screw, M5×32	4	
19	GB6170-86	螺母 M6	Nut, M6	2	
20	GB5787-86	螺栓 M8×35	Bolt, M8×35	2	
21	GB93-87	弹垫 4	Spring washer, 4	3	
22	GB818-85	螺钉 M4×14	Screw, M4×14	2	
23	GB97.1-85	平垫 4	Washer, 4	2	

E-15 启动控制盒总成(选用) STARTING MOTOR CONTROL BOX ASSY

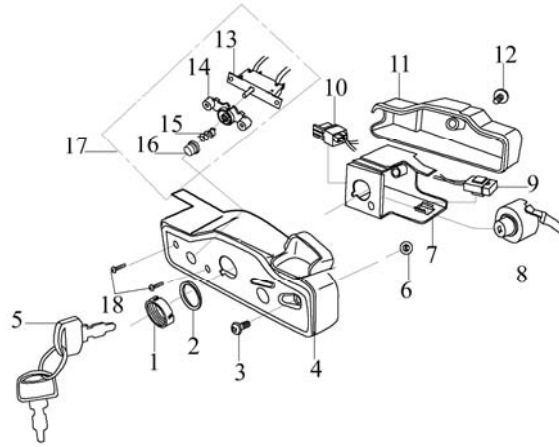

序号 S/N	零 部 件 代 号 Part No.	零 部 件 名 称	Description	数 量 Quantity	备 注 Remark
1	35412	锁紧圈	Clamp ring	1	
2	35413	钥匙开关垫圈	Gasket	1	
3	GB818-86	螺栓 M4×10	Bolt M4×10	1	
4	35322	控制盒前盖	Control front cover	1	
5	35411	钥匙	Key	1	
6	GB6187-86	六角法兰锁紧螺母 M4	Nut M4	1	
7	35331	控制盒内支撑架	Fixed mount	1	
8	35420	启动钥匙开关	Key switch	1	
9	35240	保险	Safety	1	
10		二极管组合	Diode assy	1	
11	35341	控制盒后盖	Control rear cover	1	
12	35345	后盖连接螺栓	Attachment bolt	1	
13		线路保护器	Protector	1	
14		线路保护器支架	Fixed mount	1	
15		弹簧	Spring	1	

E-15 启动控制盒总成(选用) STARTING MOTOR CONTROL BOX ASSY

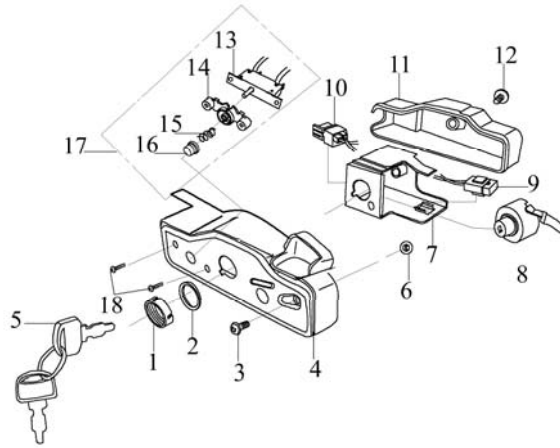

序号 S/N	零部件代号 Part No.	零部件名称	Description	数量 Quantity	备注 Remark
16	GB818-85	线路保护器帽	Cover	1	
17		线路保护器组合	Protector assy	1	
18		十字半圆头螺钉 M3×12	Bolt M3×12	2	

E-14 贴花 EMBLEM



序号 S/N	零部件代号 Part No	零部件名称	Description	数量 Quantity	备注 Remark
1	68121	控制盒贴花	Emblem, control system	1	
2	68122	铭牌贴花	Emblem, nameplate	1	
3	68231/173F	阻风门开关贴花	Emblem, choke lever	1	
4	68129	型号贴花	Model label	1	
5	68123	手启动贴花	Emblem, hand	1	
6	68124/168F	注意高温贴花	Emblem, Hi-temp	1	
7	68228/168F	注意一氧化碳贴花	Emblem, Notice: CO	1	
8	68211/168F	注意燃油贴花	Emblem, fuel	1	
9	68223/168F	空滤器保养贴花	Emblem, maintenance of air cleaner	1	
10	68225/168F	注意使用前加机油贴花	Emblem, Note: add oil before using	1	
11	68213/182F-AS	负极贴花	Emblem, “-” pole	1	
12	68212/182F-AS	正极贴花	Emblem, “+” pole	1	
13	68222/168F	加注机油贴花	Emblem, adding oil	1	
14	68226/168F	龟兔贴花	Emblem, tortoise and rabbit	1	



重庆力帆内燃机有限公司

Chongqing Lifan Power Co., Ltd.

重庆力帆内燃机有限公司

地址：重庆市南岸区海棠新街 38 号

电话：(023) 61663497

传真：(023) 61663498

邮编：400064

网址： www.lifan.com.cn

电子邮件： lfcc@vip.sina.com

Chongqing Lifan Power Co., Ltd.

**Add: N0.38 Haitang New Street Nanan
District Chongqing**

Tel: (023) 61663497

Fax: (023) 61663498

Postal code: 400064

[http:// www.lifan.com.cn](http://www.lifan.com.cn)

e-mail: lfcc@vip.sina.com

2006 年 6 月第一版